

RADIO SET RF-10

OPERATING INSTRUCTIONS

1979

GUARANTEE CONDITIONS

The manufacturer is responsible for the quality of the complete RF-10 set within the meaning of these instructions for 12 months of operation or 24 months of storage (as specified in paragraph 128a) from the date of receipt of the kit. The date of receipt is given in the kit data sheet.

The warranty does not apply:

- a) To kits which have undergone periodic tests or tests for durability and reliability (must be included in the accompanying documentation),
- b) To damage caused by extraordinary circumstances,
- c) For damage caused by the buyer, by unauthorized person(s), by improper handling, use for a different purpose and operation than that for which the equipment is designed,
- d) if involved in a crash during transportation,
- e) In the event of a violation of the case seal, the ISS officer decides on the warranty or non-warranty repair together with the PSO,
- f) On the QN 732 10 battery pack that has not been serviced according to these "Operating Instructions".

The purchaser may not make repairs in the warranty period without the supplier's consent.

Warranty repairs are carried out by the manufacturer.

INTRODUCTION

Radio set RF-10 is a portable FM radio set, designed for command of the platoon-company level, which can be operated by 1 man.

The radio set set is supplied complete with its own accessories for common modes of operation. These accessories can be carried in operation together with the radio set in a bag.

For transporting or carrying out of the kit is supplied with a specially designed shipping container.

The radio set can be transported by rail, cars, off-road vehicles and aircraft without damage.

The ways of using the radio set and accessories are dependent on combat, terrain and weather conditions.

CHAPTER 1

SPECIFICATIONS

The radio set kit meets the following specifications:

Frequency range:	44.000 to 53.975 MHz
Channel spacing:	25 kHz. All 400 channels are set directly with 3 switches
Operating mode:	Single-channel simplex telephony, frequency modulation
Transmitter power:	rated power 1W
Audio frequency power:	0.1 to 30 mW
Receiver sensitivity:	0.5 μ V
Range:	– with the 1.5m whip antenna – 5 km; – with the 0.5m whip antenna – 1 km; – with the suspension antenna (3.3 m) – 10 km; – with the directional long-wire antenna (30 m) – 20 km (Under average conditions in moderately wooded terrain)
Operating temperatures:	Working temperature range –35°C to + 60°C. In the temperature range of –50°C to + 70°C, the radio sets are operable with reduced parameters.
Power supply:	5 x NiCd 4 Ah batteries with a total voltage of 6 V
Operating time:	On one charge of batteries, at the ratio of RX:TX = 5:1, is 10 hours.
Weight of radio set kit:	About 3 kg
Dimensions of your own radio set with batteries:	295×47×191 mm
Weight of the kit in the shipping container:	8.1 kg
Dimensions of the kit in the shipping container:	450×350×160 mm

CHAPTER 2

DESCRIPTION OF EQUIPMENT AND KIT LIST

1. Composition of the kit

The RF–10 radio set consists of the following parts:

- 1 piece radio set RF–10;
- 2 piece battery packs (including batteries)
- 1 piece microphone;
- 1 piece of an antenna 1.5 m long;
- 1 piece rod antenna 0.5 m long;
- 1 piece suspension antenna 3.3 m long with spool;
- 1 piece directional long–wire antenna 30 m long with spool;
- 1 piece suspension cord 20 m long with spool;
- 2 pieces of strap;
- 1 piece of cross strap;
- 1 piece of radio set bag;
- 1 piece of power pouch;
- 1 piece record book;
- 1 piece datasheet;
- 1 piece operating instructions;
- 1 piece list of items in the set;
- 1 piece of transport packaging;
- 1 piece padlock & key;
- 1 set of spare components (by list)

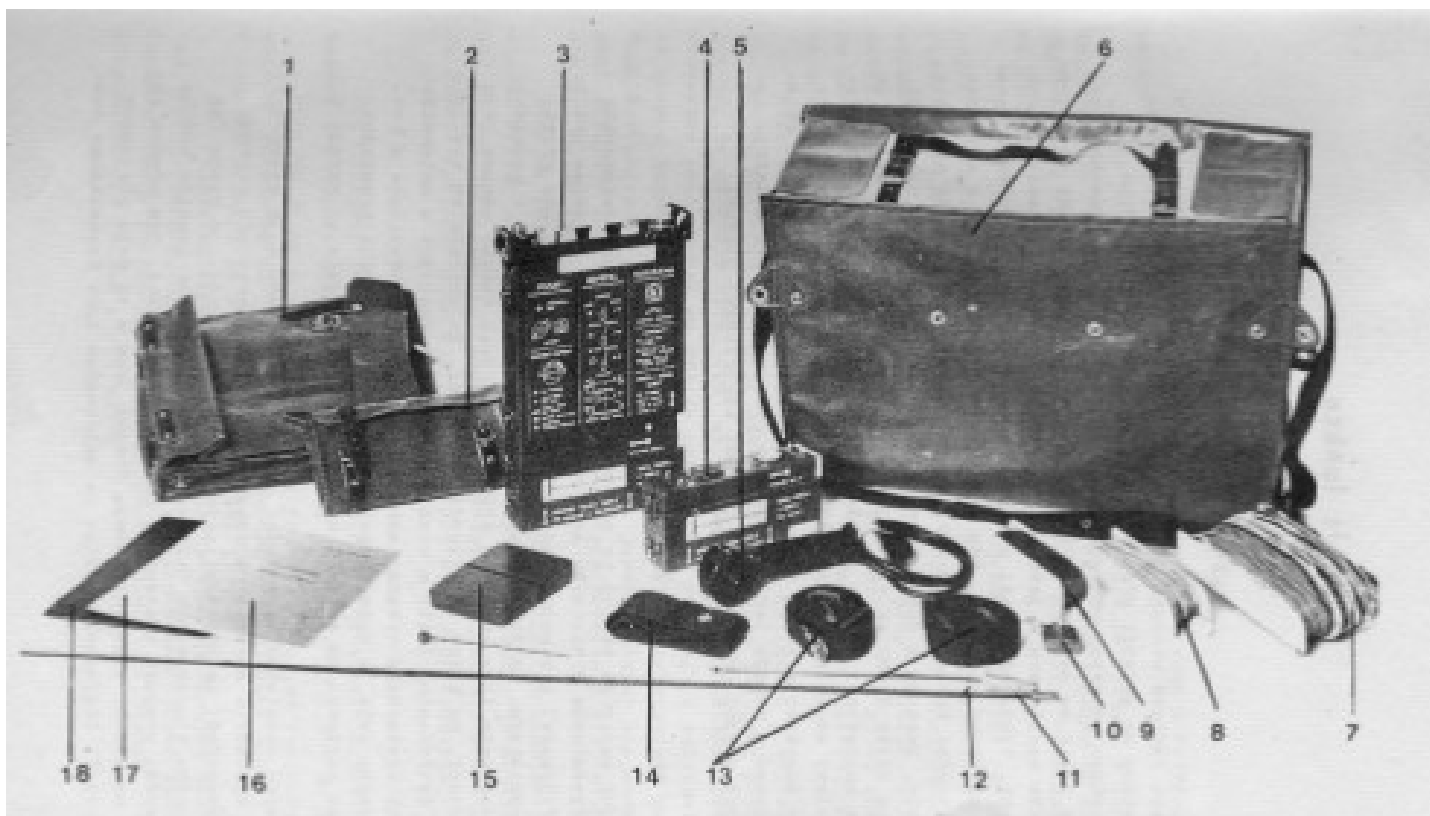

Figure 1: Complete radio set kit

1 – radio set bag; 2 – battery pack bag; 3 – radio set RF-10; 4 – battery pack (including batteries); 5 – handset; 6 – shipping container; 7 – directional long-range antenna 30 m long with spool; 8 – suspension antenna 3.3 m long and spool; 9 – suspension rope with spool; 10 – padlock with keys; 11 – 1.5 m whip antenna; 12 – 0.5m whip antenna; 13 – straps; 14 – transverse strap; 15 – set of spare components (by list); 16 – record book; 17 – technical data sheet; 18 – operating instructions

2. Functional description

a) Receiver

The receiver of the radio set is double conversion superheterodyne. The signal from the antenna is fed through relay contacts to the RF input. Here it passes through a tuned bandpass filter, through the RF amplifier, then to a four-stage filter to the first mixer. The first local oscillator frequency for mixing is fed from the main oscillator and its frequency is in the range 50.000 and 59.975 MHz. The resulting 6 MHz signal is fed through a crystal filter to the second mixer, where it is mixed with the 5.9 MHz signal from the second local oscillator giving a second IF of 100 kHz. There it is filtered in a bandpass filter, limited and demodulated. From the demodulator output, the signal is fed through an 8 kHz filter to the noise limiter input. The actual audio signal is fed to the audio amplifier via the frequency adjustment circuits. It is also routed to the 19-pin radio set front panel connector. The output of the amplifier is fed to the handset via the same connector. The noise limiter controls the amplifier and the so-called "idle" operation of the radio set. Tuning of the receiver is done by capacitance diodes.

b) Transmitter

The desired output frequency is generated by mixing an unmodulated signal fed from the main oscillator (identical to the signal for the first mixer receiver) and the modulated 6 MHz frequency signal output from the modulator. The 6 MHz modulated signal is obtained by multiplying the frequency of 400 kHz in the modulator. This circuit includes capacitance diodes to which the audio signal is fed. The transmitter mixer includes a quadruple filter and own transmitter amplifier with automatic output power control. Between the transmitter final stage and the antenna relay contacts is a low pass filter to prevent harmonic frequencies reaching the antenna.

The microphone signal amplifier is equipped with a dynamic compressor. In order to improve the transmission properties when operating in a noisy environment, the dynamic compressor is used. Undesirable parts of the speech spectrum are filtered out before being fed to the modulator. As in the receiver part, the four-stage filter is also tuned to the transmitter by the capacitive diodes.

c) Frequency generation circuits

A frequency synthesiser with a frequency divider is used in the radio set.

The signal for receiver and transmitter mixers is generated in a voltage-controlled oscillator, which operates in the 50 to 60 MHz band. The mixer of the receiver and the transmitter is connected to the oscillator via a buffer amplifier.

Although the logic integrated circuits used are very fast and the dividers are synchronous, it is not possible to count reliably the required number of pulses as set by the control dials at a repetitive frequency higher than 5MHz. Therefore, additional auxiliary circuits are included between the user and the controlled dividers, namely a mixer which converts the oscillator output from 50 to 60 MHz down to the 10 to 20 MHz band; and an auxiliary divide by four circuit, which further changes this frequency into the range of 2.5 to 5MHz.

Frequency comparisons of the precision oscillator frequency are performed at a frequency of 6.25 kHz, the partitioning of the dividers and the circuitry is such that it allows the selection of anything between the 400th and 799th pulse. After counting the required number of pulses, the dividers automatically reset and then start counting again. The resetting circuitry is compared with a reference frequency of 6.5 kHz. The output DC voltage of this comparator is used to control the frequency of the oscillator.

All the reference frequencies for radio set circuits are derived from a crystal-controlled 1.6 MHz oscillator. From this oscillator is derived the 40 MHz signal required for auxiliary measurement in the frequency reference and the frequencies of 6.25 kHz & 400 kHz for the transmitter modulator.

d) Supply and auxiliary circuits

To power some circuits in the station, it is necessary to stabilize the voltage from the 6 volt battery, which can varies between 5.3 and 7.8 V

In addition, a 12V and a 22.5V supply are required to power the Transmitter. The radio set therefore contains a stabilised voltage converter.

To ensure a long battery life in reception mode, the radio sets have a circuit which interrupts the power of the receiving circuitry and the frequency generator. The operation of this circuit is controlled by a carrier detection circuit in the.

In addition to the antenna relay contacts, there is a semiconductor circuit in the set that expands the operation of the relay. The operation lamp is used to indicate the status of the set.

CHAPTER 3

DESCRIPTION OF USAGE

1. Storing and wearing a radio set

a) Storing

The assembly of the package in the shipping container is shown in Figure 2. A list of the kit and its layout is attached to the packaging.

b) Wearing

Portable radio set RF-10 is equipped with a bag and a set of straps. The straps allow carrying the set both with and without a bag on the operator's back or chest. The radio set and the bag have mounting points to which the straps are attached. The straps can be adjusted by pulling the free end. The strap is in 2 parts and the pair of buckles are provided to ensure that the two parts of the straps are attached to each other. The upper end of the strap is marked in blue.

The design of the bag allows the radio set to be used while in it's bag and the control panel is covered. In this way, the control panel is protected against rain, dust, etc. The antenna and the wiring for the handset pass through the relevant openings in the cover, which can be accessed from the inside of the cover (see Figure 5).

By the use of the two straps supplied, the radio can be carried either on the operator's back or chest. The position of the radio set on the back is shown in Figures 7, 8 and 9. When placing a radio set and it's bag on the back, an additional short hooked strap on the bottom of the bag is hooked over the belt (Figure 10). With this method, it is advisable to use the transverse strap to prevent the shoulder strap from sliding (Figure 6).

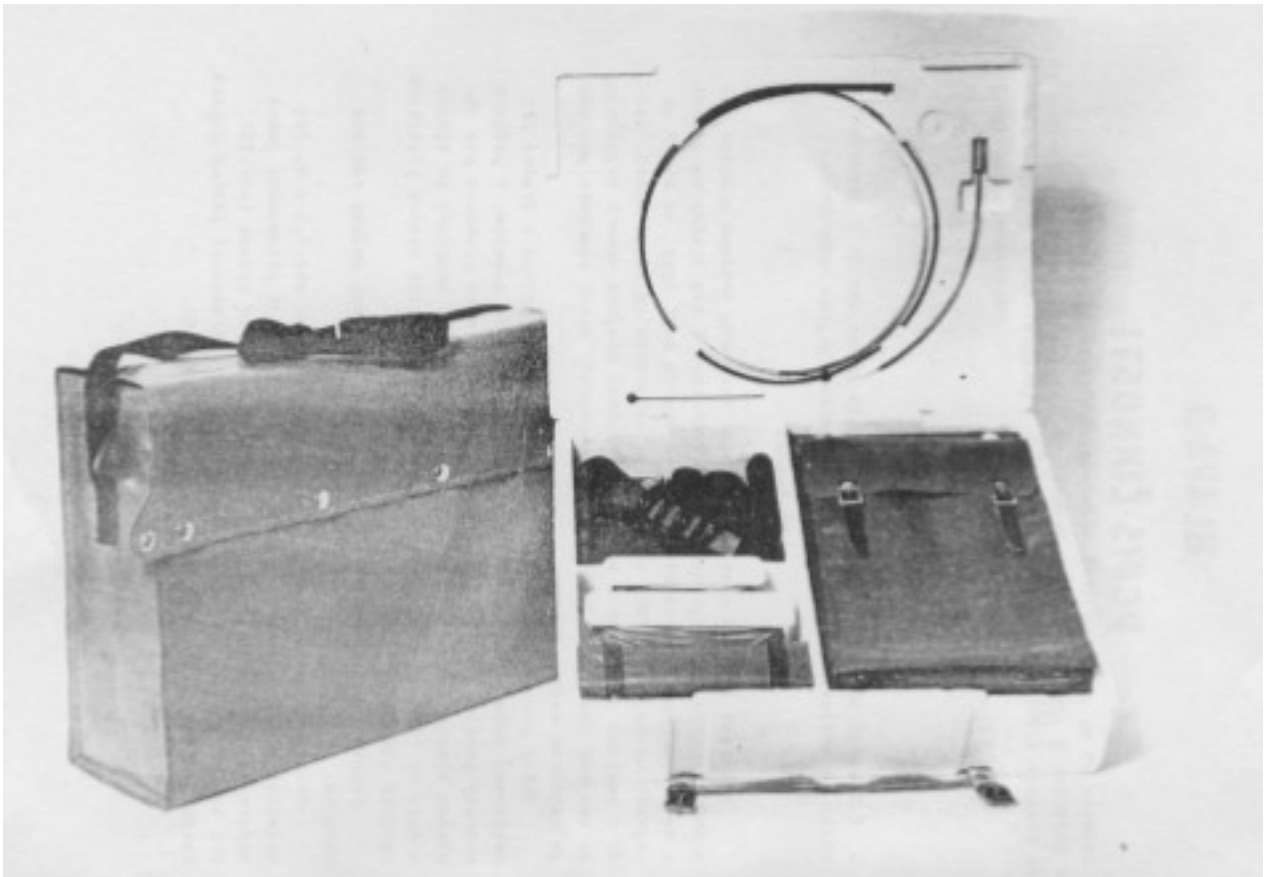

Figure 2: The radio set in the shipping container



Figure 3: Radio worn on the chest – front view



Figure 4: Radio worn on the chest – rear view



Figure 5: Radio worn on the chest



Figure 6: Radio worn on the back – front view



Figure 7: Radio worn on the back – rear view



Figure 8: The radio in a bag worn on the back – rear view – spare battery bag vertical



Figure 9: The radio in a bag worn on the back – rear view – spare battery bag horizontal



Figure 10: Attaching the bag to a belt

The position of the radio set on the chest is shown in Figures 3, 4 and 5. The radio set can be attached with one strap on the waist, the other around the neck (Figure 3). When using the bag, secure the bag strap (Figure 10). Another possibility of attachment is in Figure 4. The straps are crossed to the back so that they do not slip off the shoulders.

For both of these positions (on the back, on the chest) two long straps from the set are used.

The backup battery that is part of the kit is stored in a separate bag. Possible ways of wearing (on the belt) are can be seen in Figure 8 and Figure 9.

2. Preparation & Operation

Remove the radio set together with the accessories from the shipping container. Attach the battery pack to the bottom of the radio and place the assembly into the bag. The batteries are permanently installed in the battery pack, which can be replaced if necessary by the backup battery.

a) Battery connection

Connect the battery pack to the bottom of the radio using the four pins into the keyed holes so that both the battery connector and the radio set are on the same side. For ease of identification, the sides of the radio set and the battery pack are also marked in white. Push the battery pack onto the radio set and slide it in the opposite direction of the arrow so that the locking pin on the battery pack fits into the spring retaining clip on the bottom of the radio set (Figure11).

In order to disconnect the battery pack from the radio, press the spring lock on the bottom of the radio towards the control panel and eject the battery pack in the direction of the arrow marked on the battery pack.

The battery pack may be connected to the radio set by means of the cable provided in the extended accessory set. This method is also used in very cold conditions, where the battery output is reduced. In this case the battery is carried by the operator under their outer garment.

Battery packs QN 732 10 produced after September 1, 1979 are not equipped with a push button and a bulb to indicate the state of charge of the battery. On units produced before this date, an indication of the status of a battery pack can be performed by pressing the button with the rubber disc on the battery pack marked "⊥". When the button is pressed, the battery light should illuminate, this check verifies whether the battery pack is defective or not.

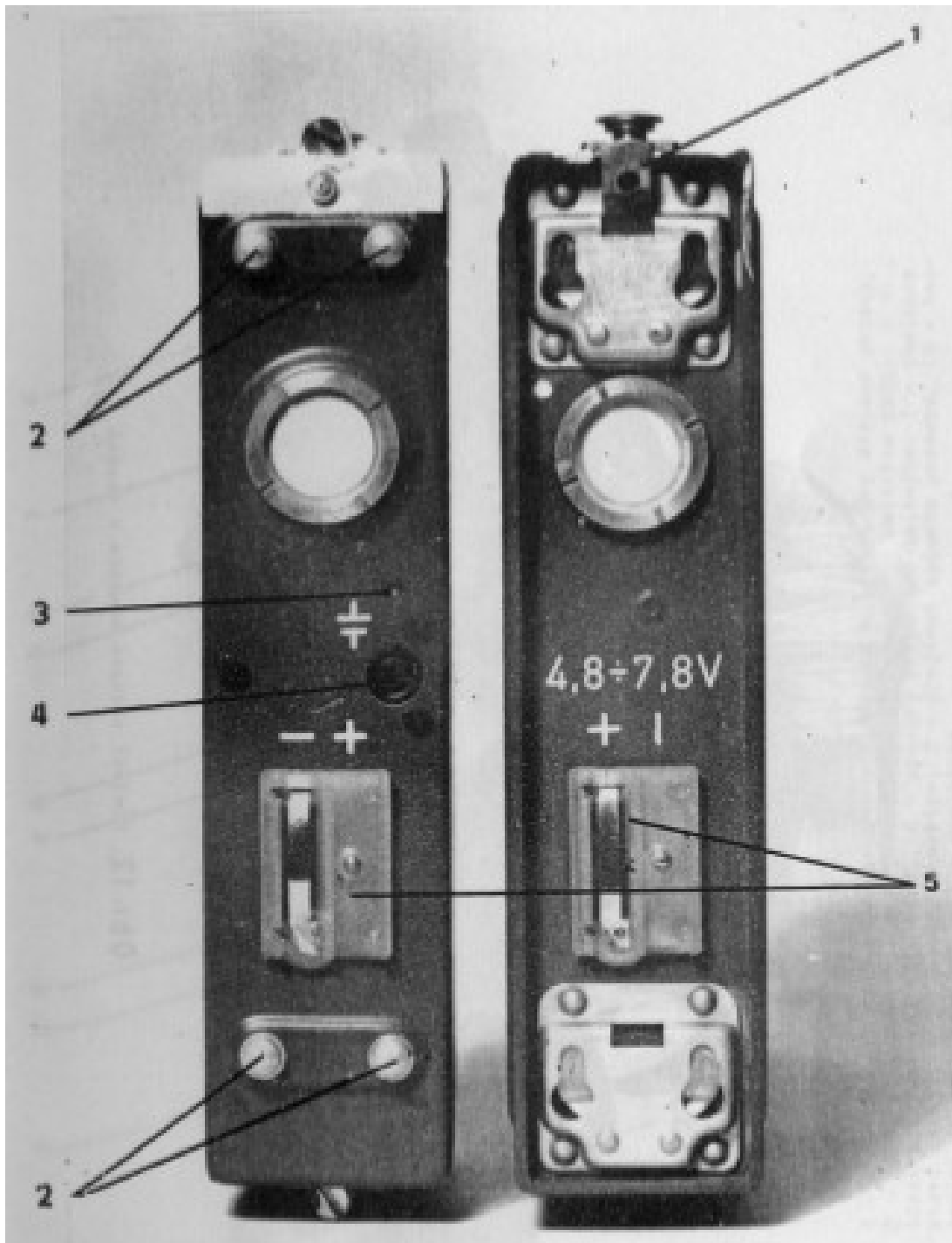

*Figure 11: Battery pack lid and bottom of radio set
 1 – locking spring; 2 – spigot pins; 3 – indicator light; 4 – test button; 5 – battery connector (Battery packs QN 732 10 produced after September 1, 1979 do not have items 3 & 4*

b) Carrying in a bag

When using the radio set in the bag, the radio set with a battery pack is placed in the back pocket, which is provided with padding and a separate cover for the control panel. In the lid are openings for the antenna and handset connectors. The radio must be oriented in the bag so that the connectors (for the handset and antenna connectors) are always on the side away from the operator's body. The radio is held in the bag by straps and buckles on the side of the compartment which are passed through the relevant holes on the side of the control panel.

The centre compartment is intended for the accompanying documentation of the radio set and for the whip antennas.

The top pocket is used stored additional radio set accessories that may be to be used later in operation.

The arrangement of the set is in Figure 12.

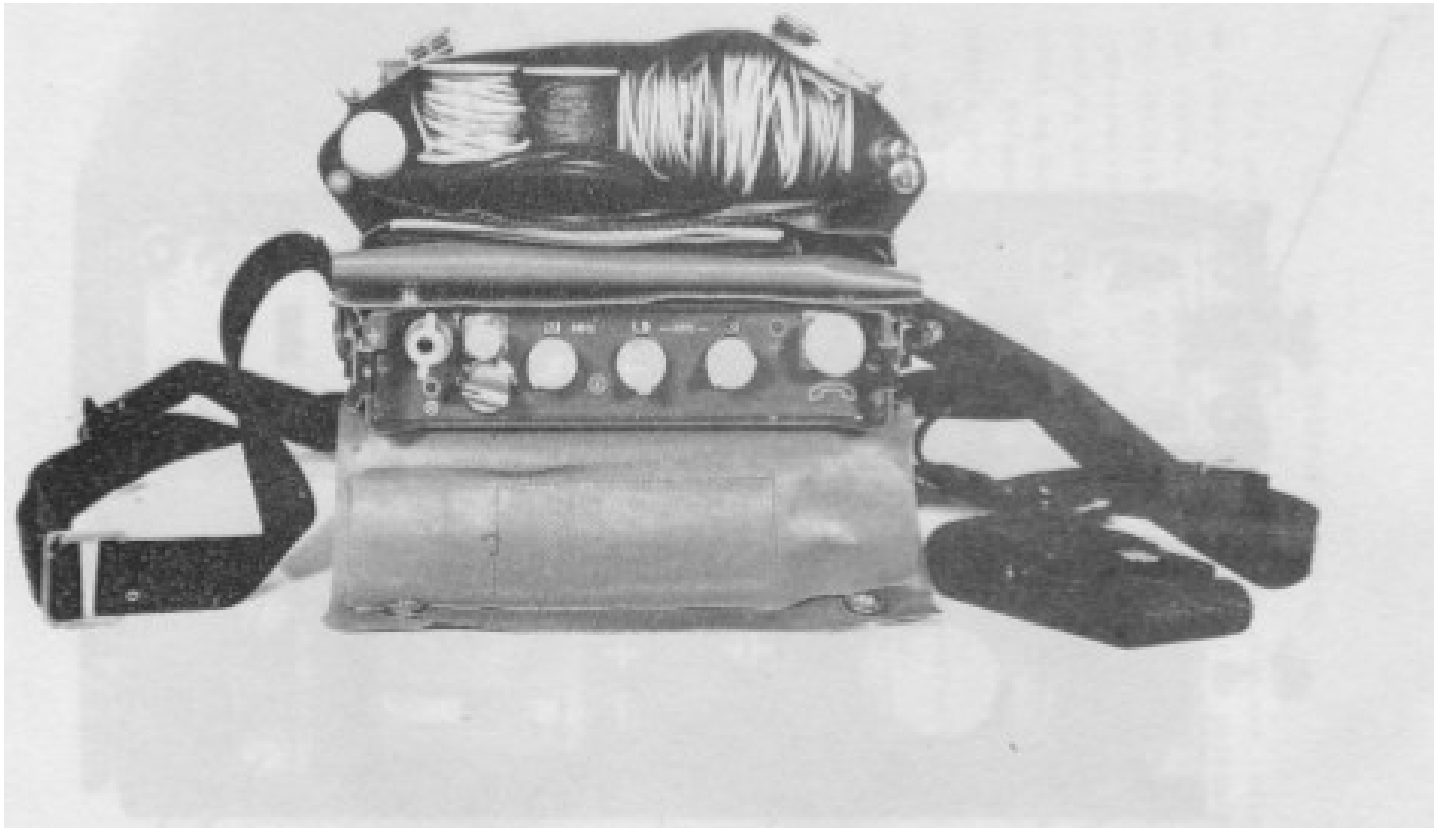

Figure 12: Storing the radio set in it's bag

3. Description of the radio set control panel

The radio set control panel is shown in Figure 13.

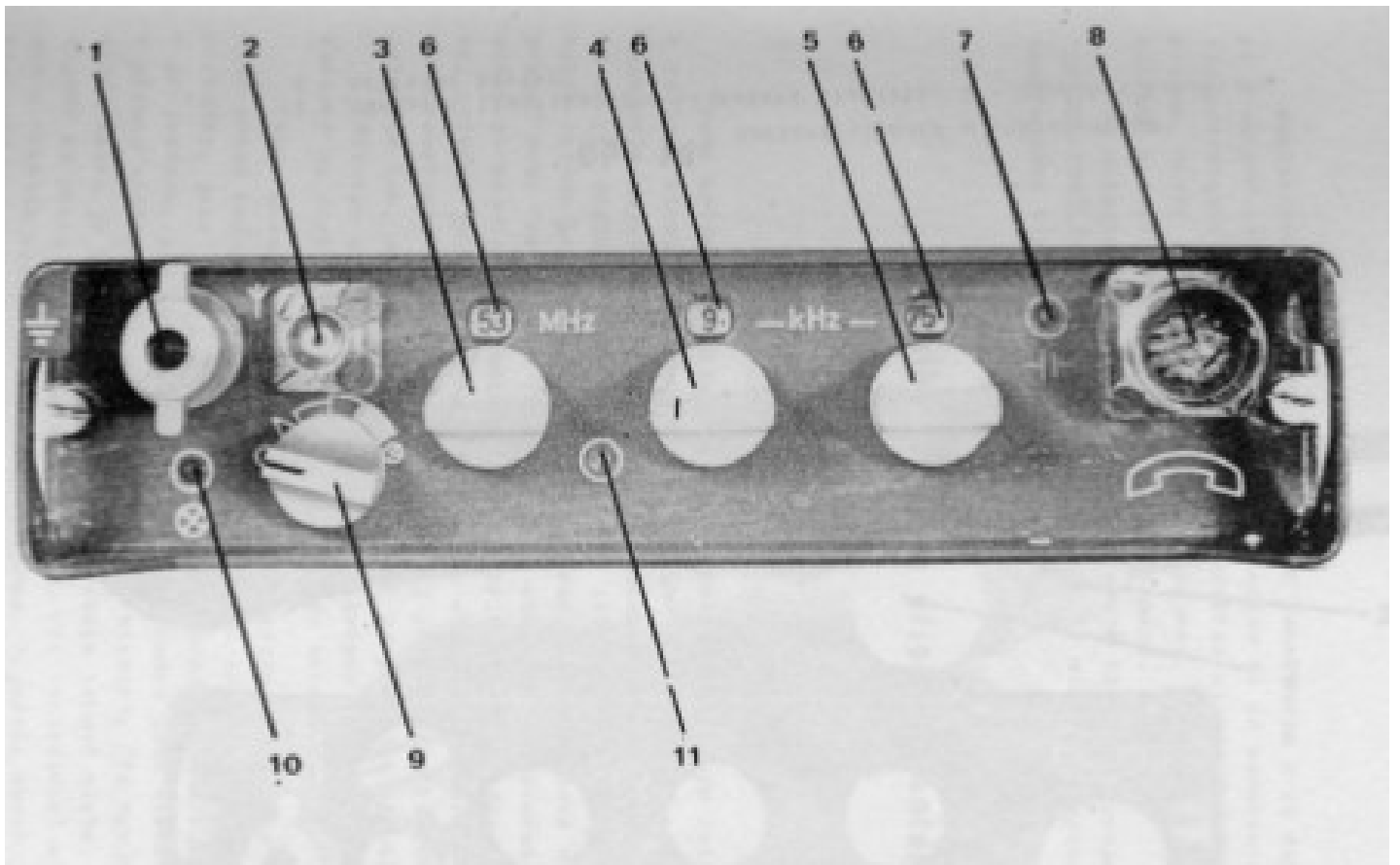
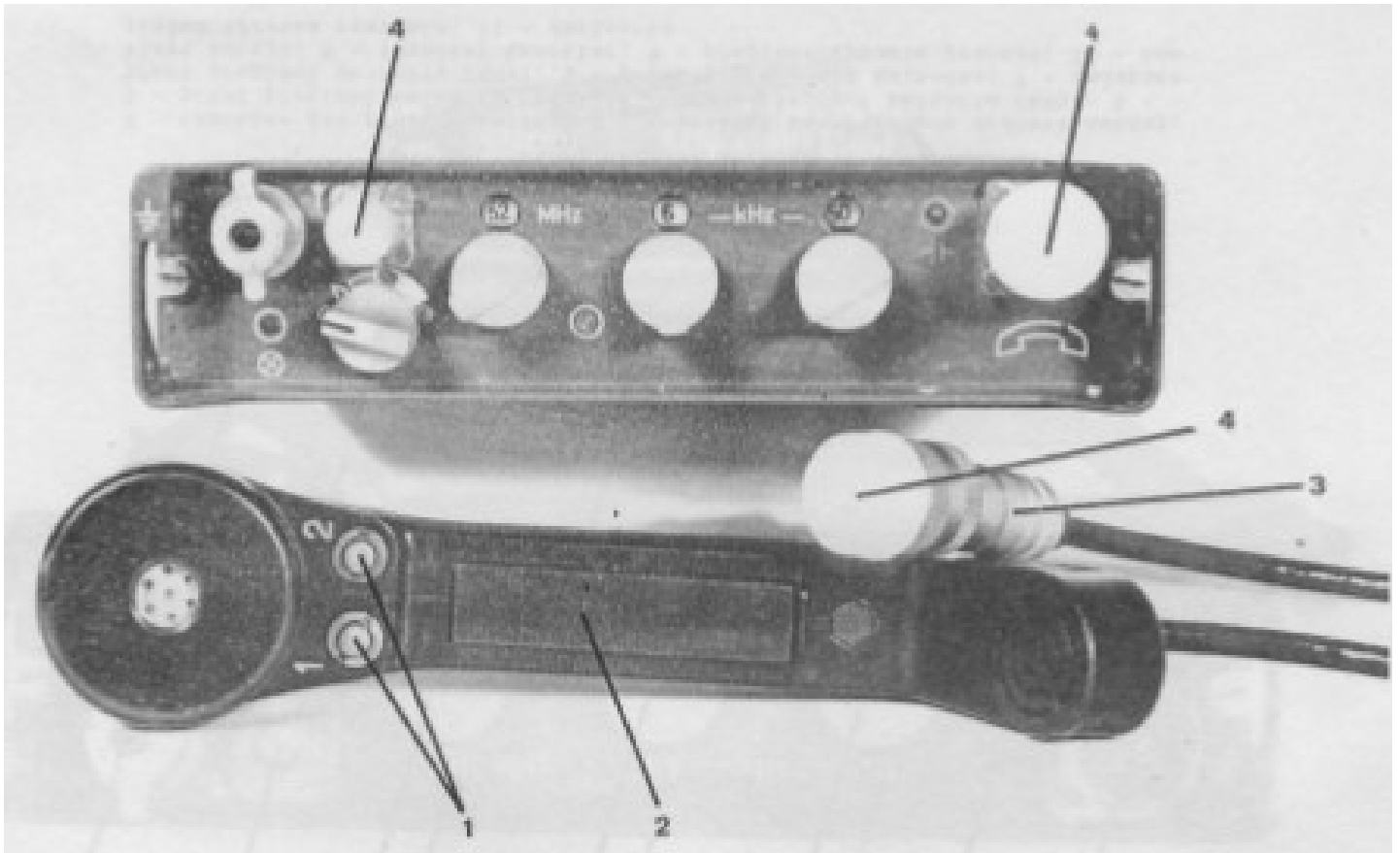

Figure 13: Radio set panel

1 – Whip antenna connector; 2 – coaxial connector for wire antenna; 3 – first frequency selector (MHz); 4 – second frequency switch (kHz); 5 – third frequency switch (kHz); 6 – frequency indicators; 7 – battery status indication; 8 – 19-pin connector; 9 – mode switch; 10 – transmitting indicator; 11 – operation indicator



*Figure 14: Radio set and handset
1 – push buttons; 2 – PTT switch; 3 – 19-pin connector; 4 – protective caps*

4. Handset connection

To connect the handset (fig.14), connect the 19-pin connector (Figure 14, item 3), first removing the cover (item 4) to the connector on the radio set panel (Figure 13, item 6). The handset connector has a key that ensures proper orientation. After insertion, push the locking ring onto the radio set connector and tighten. The includes the PTT switch (position 2). The two buttons (position 1) are used to generate tone signals. The functions of both these buttons are the same.

5. Choice and connection of antennas

a) The 1.5 m whip antenna

This antenna is the basic type of antenna used by the set. It connects to the radio set by inserting it into the antenna connector on the radio set panel and securing with the wing lock (Figure 13, position 1). When using the radio set in moderately wooded and medium terrain a range of up to 5 km can be expected. The operating position of the radio set is "on the chest" or "on the back" (see Figures 3 to 10), which is fixed to the operator's body as far as possible. It is necessary to observe the vertical position of the antenna. The rod antenna, in particular if used obliquely, does not radiate equally in all directions due to the operator's body. It is advisable for the operator to position themselves so that the end of the antenna is facing towards the opposite station (if possible).

The station can be used on the ground, but the range can be affected by the electrical properties of the terrain. **Site Selection.** When selecting the antenna, use the position of the antenna so that there are no obstacles in the immediate vicinity of the radio set, such as houses, dense forests, etc. The use of the radio set under bridges, inside the buildings, etc. will result in reduced range. The preferred position is elevated, with direct line of sight towards the other station. When connecting over longer distances, the operator needs to find a location where the signal from the other station is the strongest. When searching for such places, move a few steps forward or sideways. The greatest range is when the radio set is located on the back and when the operator is standing with their back towards the other station.

b) The 0.5m whip antenna (shortened)

The connection of this antenna is exactly the same as the previous type. It is used in cases where the antenna will either cause an obstruction (e.g. in buildings) or be well within in the station's range (e.g. at the front line). The range of a radio set in medium-wooded and medium-terrain is typically 1 km. Radio set characteristics with this antenna are the same as using the previous antenna type.

It is not advisable to use this antenna unless absolutely necessary. When possible, it is recommended to use the 1.5 m whip antennas for short distances and, only under ideal conditions, to switch to the 0.5 m antenna.

c) Suspension antenna

This antenna (Figure 15, position 3) is intended to increase the range of the radio set (up to 10 km). It is suitable for static operation, namely: in forest or rugged terrain, for operation from trenches, bunkers and buildings. These uses are shown in Figures 16 and 17.

The antenna connects to the radio directly or via an extension coaxial cable, which is part of the extended accessory kit. The actual radiator of the suspension antenna consists of a 3.3 m long insulated element, connected by a 4.25 m long coaxial cable, which is connected to the adapter by a matching coil. The suspension antenna should be mounted as high as possible, and the antenna and the coaxial cable section should be aligned vertically (Figure 18). The use of metal poles or masts to suspend the antenna should be avoided. The suspension antenna is wound onto a spool of plastic (Figure 15). At its end is the loop to which the suspension cord is attached. At the end of the cord, attach a heavier object, which can be used to throw the cord over a suitable suspension point e.g. a tree branch. The cord is then used to pull the antenna up to its operating height.

Removal of the antenna after shutdown is the reverse of this operation i.e. disconnect from the radio set, wind up the antenna onto its spool and put it in the bag. The coaxial connectors (on the antenna panel and the antenna) are protected against dirt by plastic caps.

ATTENTION! When deploying and retrieving the antenna, caution is needed – avoid an accident!

d) Horizontal directional antenna (half rhombic)

The long-range directional antenna comprises of an insulated 30m long wire with a suspension loop in the middle. At the end is a housing with a terminating resistor with three 1.8 m long radials. The lead to the antenna is the continuation of the 1.5 m long antenna's own conductor terminated with a banana. Both ends of the antenna are provided with pairs of guy ropes with adjustable lengths with a maximum length of 2 m. In Figure 15, the directional antenna is spooled – Position 2. This antenna is suitable for static operation over a distance (up to 20 km) even in the field. The antenna is directional and must be aligned with the other station. Alignment of the antenna is performed using a compass and map. The antenna must be constructed in such a way that the resistive load in the plastic cylindrical body is aligned towards the opposite station (see Figure 19). The deviation from this direction must be less than $\pm 10^\circ$. Failure to comply with this condition will result in a reduced range.

Choose the antenna structure as far as possible to be away from buildings, masts or field objects. It is not advisable to erect the antenna near a high voltage line. These objects in the antenna site affect their radiating characteristics and will reduce the range.

Antenna construction. Unpack the antenna on the ground aligned in the direction of the other station. In the centre of the antenna is a loop into which connects the clip of the suspension cord. At the other end of the cord attach an object weighing about 1 kg (e.g. a stove, etc.). The cord must be held loosely in loops of approximately 75 cm in diameter to allow it to be thrown out easily up to 10 m high. Beware of the risk of injury! Unless there is another option, it is possible to route the antenna over another more suitable object. The most suitable height of the top of the antenna is 8 m from the ground. Stretch out the antenna and use the guy ropes at the ends to anchor to pegs. The layout of the antenna is shown in Figure 19.

The antenna is connected to the radio set using an impedance transformer (Figure 22). The transformer has two sockets marked "Y", "V" and the coaxial connector to connect the transformer to the radio set. The holes are threaded, as well as the plugs. The socket labelled "Y" is for the line from the antenna. Insert the plug of the radials into the "V" socket and spread them freely on the ground. The angle between the individual wires ideally should be about 120° . The radials at the far end by antenna's terminating resistor should be spread in a similar manner (Figure 21).

e) Horizontal directional antenna (long wire)

An antenna using the same wire as described in paragraph (d) is used to construct the horizontal long-range directional antenna.

If it is not possible to erect antennas higher than 4 m in the given terrain, it is better to install the antenna horizontally (Figure 20). Spread the antenna freely on the ground in the desired direction to the opposite station. Secure the guy ropes at the ends with pegs (not part of the kit.) With the antenna remaining unstressed, the terminating resistor should be about 0.5 m from the pegs. Support the antenna at the ends (in place of the centre eyelet) and in the middle of the so that the height of the radiating wire is about 1 m above the ground. Then tighten the antenna. Connecting the antenna to the radio set is the same as the previous antenna. The range of operation for this antenna is approximately 10 to 15 km. In an emergency it is possible to connect an antenna to trees, wooden objects.

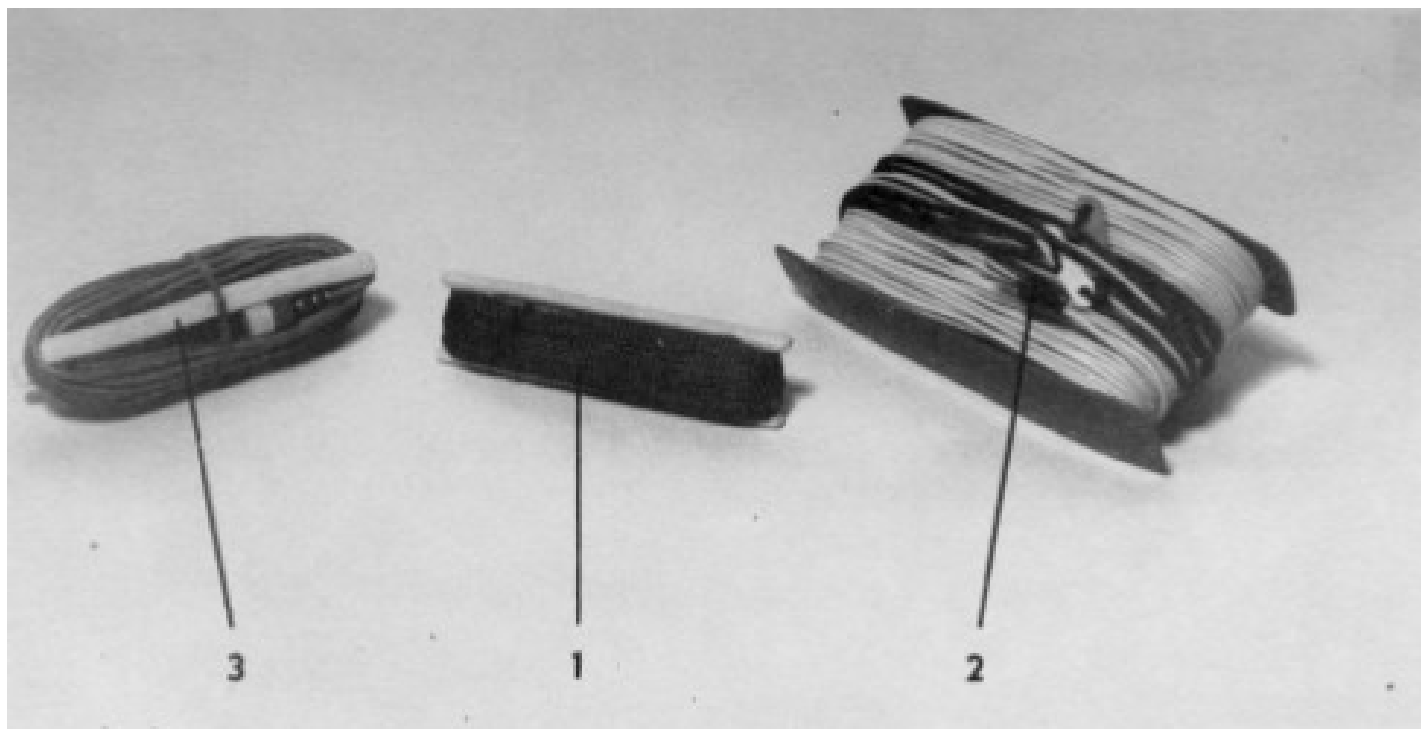

*Figure 15: Wire antennas
1 – suspension cord; 2 – directional antenna; 3 – suspension antenna*



Figure 16: Use of a suspension antenna in the field



Figure 17: Use of the antenna to use the cover provided by a wall

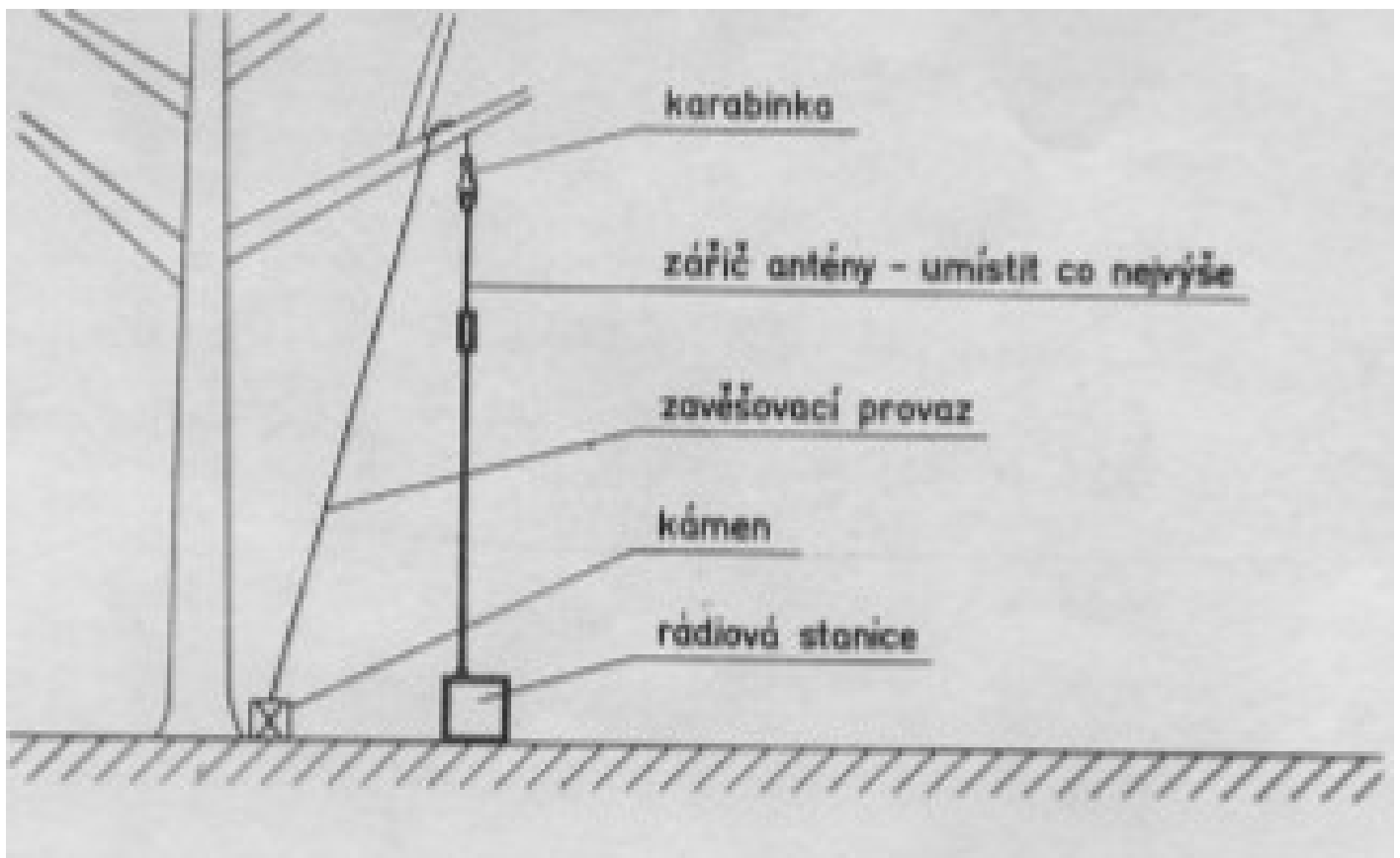

Figure 18: Suspension antenna

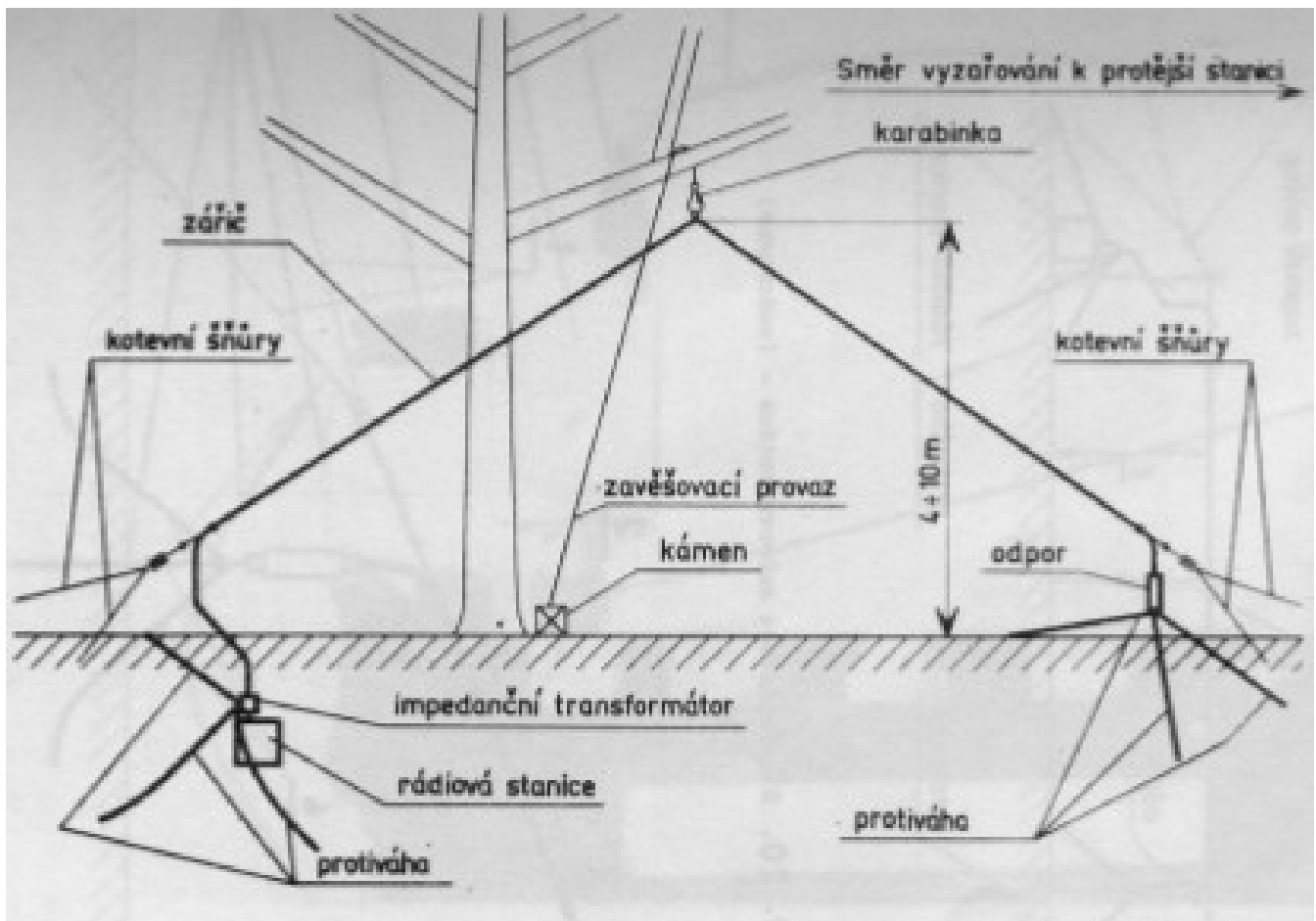

Figure 19: Directional antenna – half-rhombic

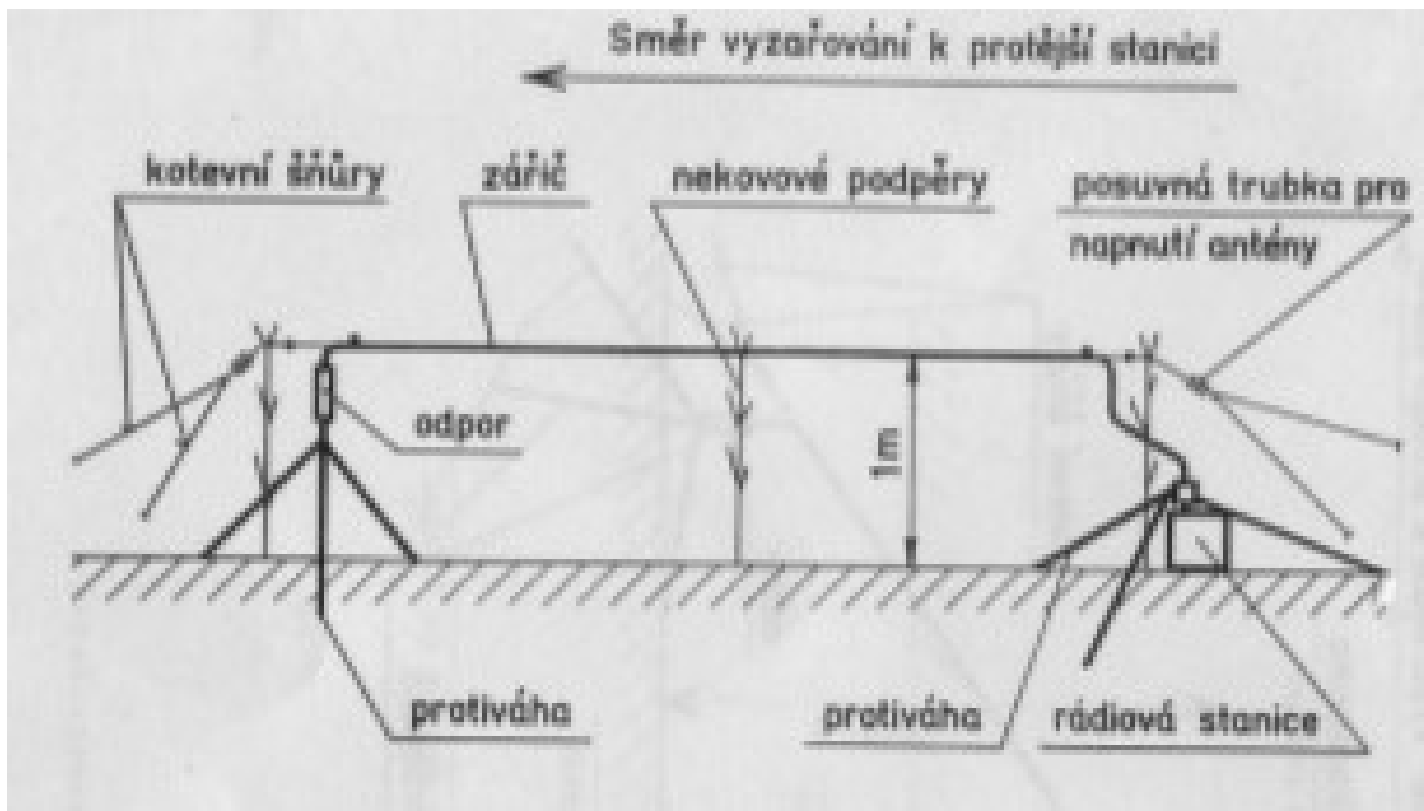

Figure 20: Horizontal directional antenna – (horizontal)

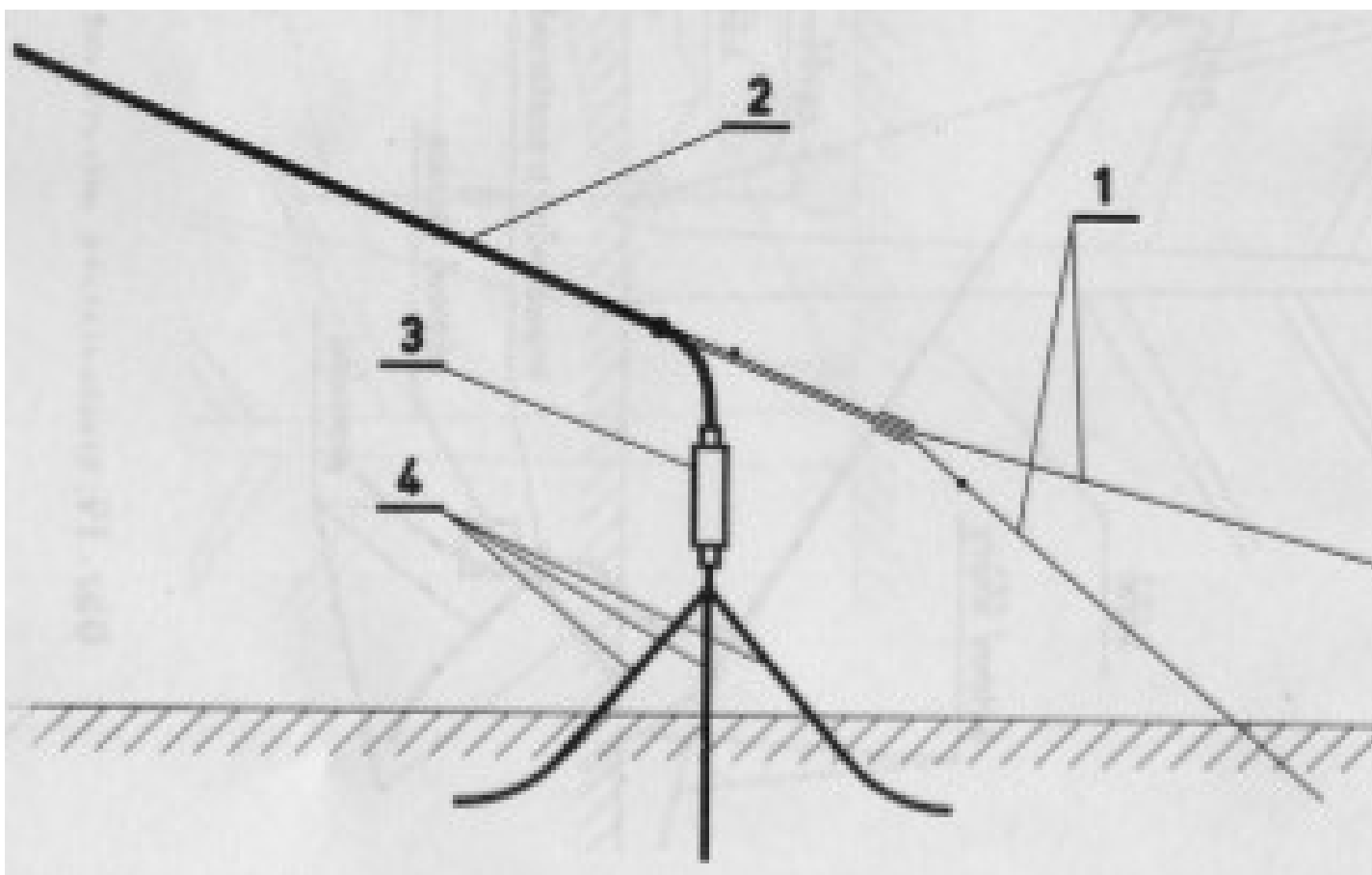

Figure 21: Terminating resistor with radials
 1 – guy ropes; 2 – part of the radiator; 3 – terminating resistor; 4 – radials

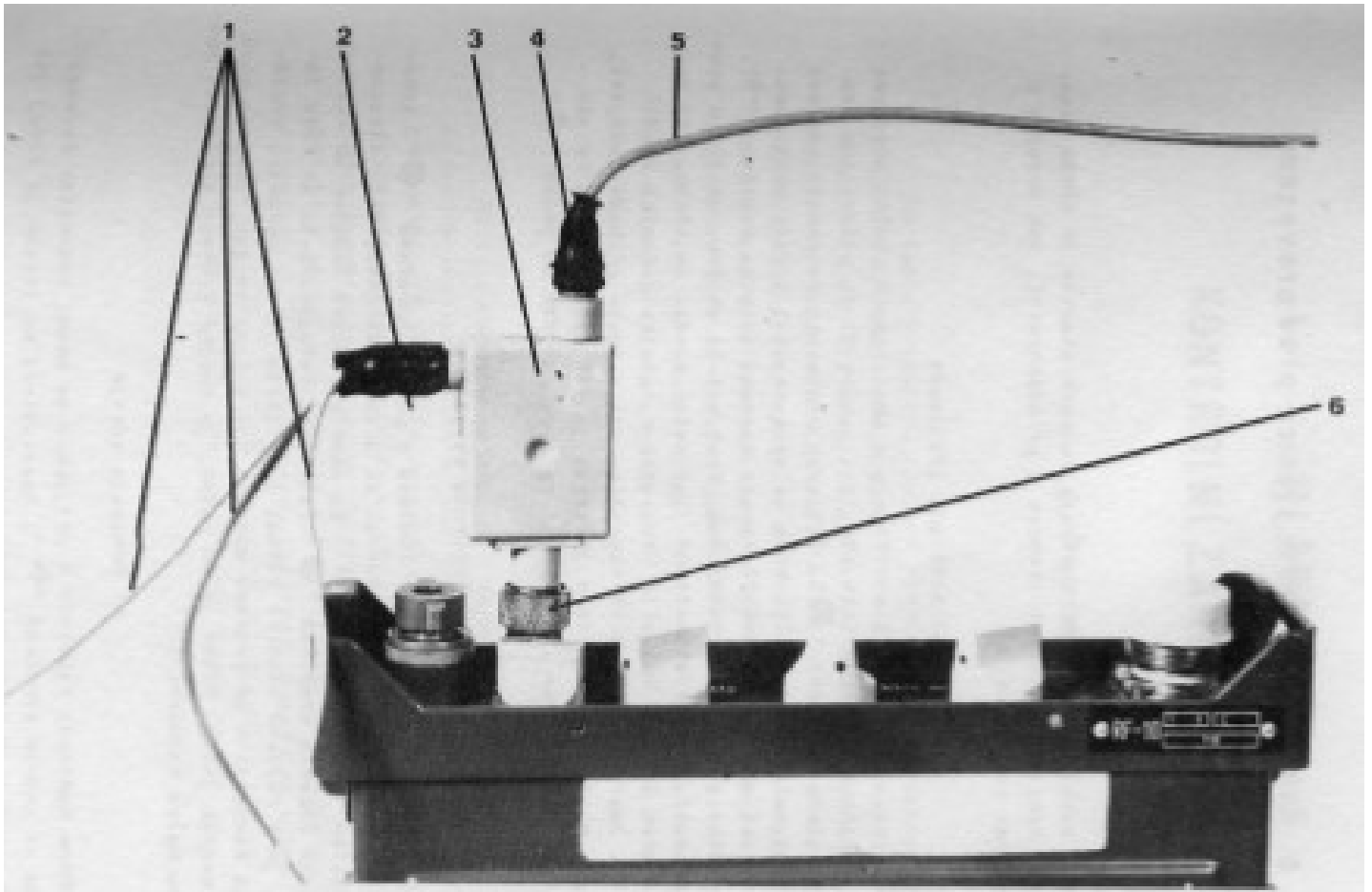

Figure 22: Impedance transformer and radials

1 – radials; 2 – radial connector; 3 – impedance transformer; 4 – antenna connector; 5 – antenna; 6 – coaxial connector

6. Checking the radio set before operation

Check the radio sets before operation; Examine the station and accessories for mechanical damage.

a) Checking the receiver

(See Figure 13 – position 9) Turn the mode switch to the test position marked "⊕", the connected circuit and the AC inverters are switched. The lamp flashes on the radio set panel signal to indicate that the radio is turned on. There the frequency indicators should glow. However, the red low battery light must not be lit. There should be noise in the handset. If there is no noise, the radio set should be tuned to a free channel. It is necessary not to set any of the frequencies listed in the problem channel table (pg. 7). If the noise in the handset does not appear in this case, the radio set needs be repaired. The noise in the handset disappears by switching the mode switch to one of the other positions.

b) Checking the transmitter

The mode switch remains in the position labelled "⊕". The antenna is disconnected from the radio set. The PTT button is pressed on the handset (Figure 14). The green bulb marked "⊕" (Figure 13) lights up on the radio set control panel. If this bulb does not light up, there is a fault in the radio set and it needs to be repaired. When performing a check with a connected antenna, the procedure is the same, but the bulb is lit by a lesser brightness. If possible, it is advisable to make contact to another local station.

c) Battery control

The red bulb on the panel labelled "⊕" must not light during the operation of the radio set. If the light turns on permanently, the battery is already drained and needs to be replaced or recharged.

CHAPTER 4

TEST EQUIPMENT KZ-10

1. Description

Checking the radio set and battery status is enabled by the use of a control device. It is also used for initial problem investigation No. 1. (TO. 1). The control of the parameters and basic functions of the radio set is only informative. This device allows you to check the battery voltage, the operation of the radio set when receiving and transmitting, the transmit power, the sensitivity of the receiver, and to use the radio set for short distances. In addition, a DC voltmeter for DC voltages of up to 10 and 30 V can be used.

a) Connecting the control device

Unplug the battery pack from the radio set. Connect the control device to the radio set in place of the battery pack. Attach the battery pack to the control unit. The method of connection is the same as connecting the battery pack to the radio set. Connect the cable with the 19-pin connector to the connector to the 19-pin connector on the radio set control panel (Figure 18, position 8) instead of the handset. Then connect the handset to the control unit 19-pin connector (2) of the control unit. A coaxial cable with connector (3) is connected to the wire antenna connector of the radio set (Figure 13, position 2). The complete assembly is shown in Figure 23.

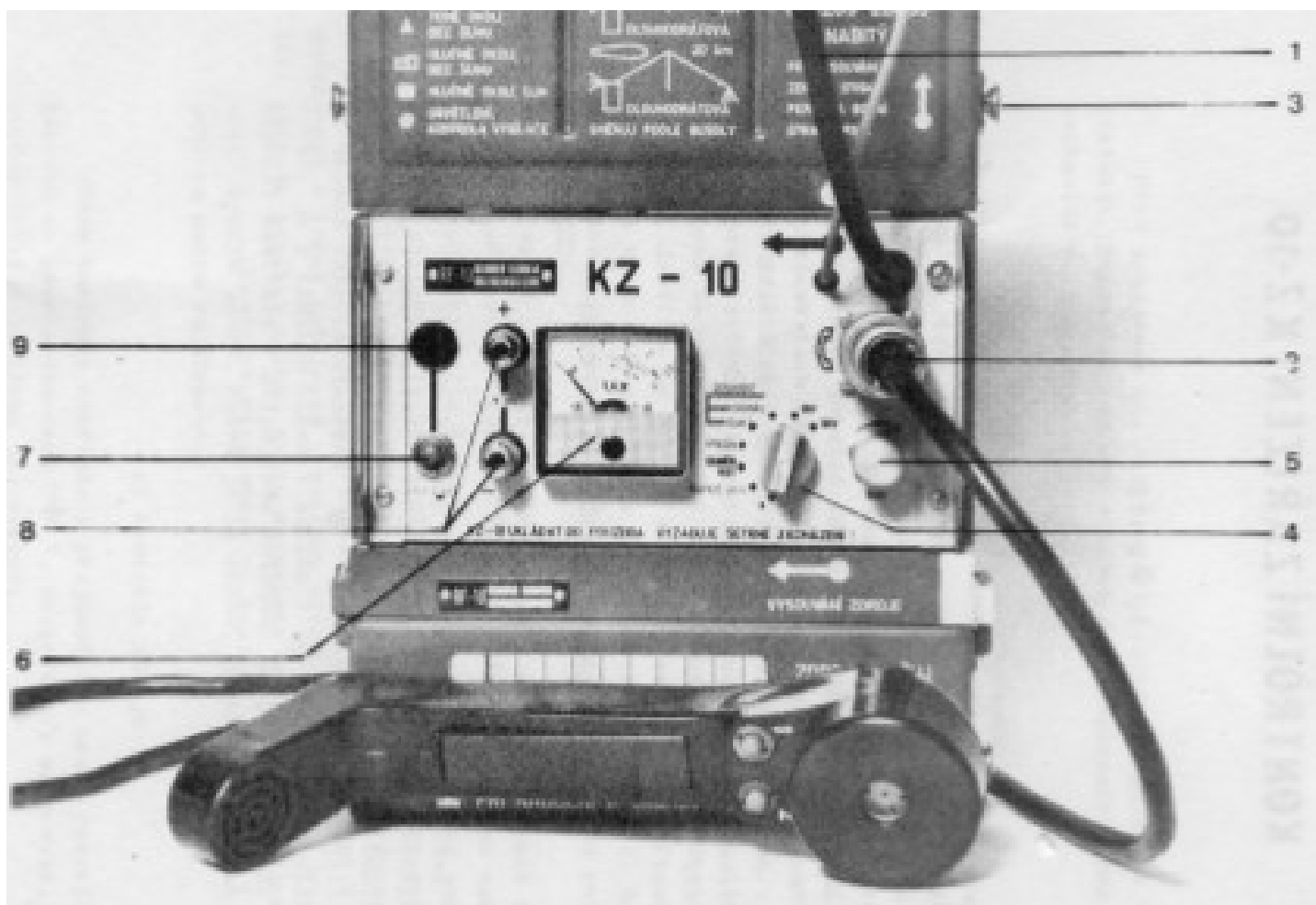

Figure 23: Control device KZ-10

1 – 19-pin connector cable; 2 – 19-pin handset connector; 3 – coaxial cable with connector; 4 – function switch; 5 – audio level adjustment; 6 – meter; 7 – "LOAD" button; 8 – terminals; 9 – "LOAD" button

2. Check the radio set

a) Checking the battery pack

Switch the switch (position 4) to the "VOLTAGE" position. With the radio set off. The meter (position 6) shows the voltage of the battery pack. Pressing the (7) "LOAD" button (7) tests the battery pack by applying the maximum current that the radio set should require, the "LOAD" light (9) will light up. Rated power supply voltage is 6 V. A charged battery should have a voltage within the red area. The meter reading must not fall below the bottom of this area. If the power supply voltage is lower than the lower limit, it is necessary to charge the battery pack immediately.

b) Checking radio set current consumption

Switch the switch (4) to "CURRENT". Switch the radio mode switch to the "■" Position. The meter (6) should show between 230 and 300 mA. When switching the microphone on the transmitter, the meter should indicate between 750 and 950 mA. When switching mode switch mode to the position "Δ", "◻", "□", current draw should be between 80 and 150 mA. The reading on the meter should vary – as the radio set operates in intermittent mode. However, listening to the handset should check whether the radio set is receiving the signal.

c) Checking reception sensitivity

The radio set is switched to the "■" switch of the mode of operation. The radio set is tuned to the frequency set on the control panel. Turn the control switch (4) to "SUM". The deviation of the scale (6) is set by the knob (5) to full deflection so that the gauge does not drop below the level marked by the blue field at the end of the scale. If the control device switch (4) is set to "SIGNAL", the meter drops to the blue field at the start of the scale.

d) Checking the transmitter power

The radio set is switched to one of the "Δ", "◻", "□", "■" modes, the control device switch (4) in the "RF POWER" position. Press the PTT key to switch to radio transmit. The needle of the meter (6) points to the green field i.e. a power greater than 0.5 W marked by a scale at the beginning of the green field. This check is only correct if the check under paragraph (a) has been met. It is sufficient to connect the connector (3) to the coaxial connector on the radio set panel (position 2 – fig.13). The control device can therefore be used to measure the performance of the radio set separately.

3. Voltage measurement

The control device can be used as a voltmeter for DC voltage in the range of 0 to 10 V and 0 to 30 V. Connect the voltage to be measured to the terminals (8) according to the polarity and the voltage is read on the meter (6). Selecting either measuring ranges is done by the switch (4).

Note

Disconnecting the control device is done in the opposite way to the connection. It is first necessary to turn off the radio mode switch and the control device switch (4).

Notice

The exact operating instructions for the KZ–10 Controller are listed in the accompanying documentation of the KZ–10 Controller.

CHAPTER 5

OPERATION

1. Tuning radio sets

a) General

After preparing, checking the radio set, after the antenna is connected, the radio set can be tuned to the specified frequency. The tuning is done by setting the three switches in the central part of the control panel of the radio set (see Figures 13 and 14).

The first switch labelled "MHz" and the numbers "44" to "53" are used to set the frequency from 44 to 53 MHz at 1 MHz intervals.

The second switch marked "kHz" (centre) and marked "0" to "9" is used to set 100 kHz frequencies.

The third switch labelled "kHz" with the numbers "00", "25", "50" and "75" is used to set the frequency of the radio set in steps of 25 kHz.

The switches are equipped with end stops. The preset frequencies of the radio set can be read through the indicators adjacent to the relevant frequency switches. In the "⊗" switch mode, the switch indicators are illuminated in the view ports to help you adjust the frequency of the radio set in the dark. In other positions of the mode switch, the frequency switch indicators are not illuminated.

b) Frequency setting procedure

Switch the mode switch to position "⊗".

Frequency, e.g. 49.675 MHz. Set as follows:

- the first switch to number "49" in the left-hand side of the window;
- the second switch to number "6" in the central window;
- the third switch to number "75" in the right-hand window.

In this way, a total of 400 channels can be set up to 25 kHz channel spacing between the frequency of 44.000MHz to the frequency of 53.975MHz inclusive.

2. Setting the mode switch

Set the switch to the positions selected according to the following table:

	Noise reduction	Ambient noise	Microphone sensitivity	Handset Volume	Operation	Use
Δ	On	little	high, even	Low	economical	Front line, intelligence
◻	On	medium	normal	medium	economical	Normal conditions
□	On	medium to high	normal	maximum	economical	In vehicles and noisy environments
■	Off	medium to high	normal	Medium, no signal noise	permanent	Difficult conditions, noisy environment
⊗	Not suitable for traffic					Serves for transmitter control, scale illumination
○	radio set off					

For good field conditions, use the operating mode switch positions "Δ", "◻" or "□" (intermittent receiver operation). The sensitivity of the receiver will not deteriorate during this operation. This significantly increases the station's operating time. In cases of bad terrain conditions and long distances to the other station, use the position of the mode switch "■".

Principle. It is always advisable to use so-called "Noise Operation" (switch position "■") for the connection,

and only then, if possible, to switch to so-called "economy" (intermittent reception).

Note. When using 1.5 mm long rod antenna, it is not allowed to cut it by bending, bending, or attaching the antenna end to it.

3. Volume control

The reception volume is controlled by the mode switch and the radio set is always assigned to the selected operation. In the first position, a so-called "modulation amplifier" compressor amplifier is also switched on, ensuring proper transmission modulation. A whisper is enough to produce modulation of the station. It is used, for example, in the night, near the position of the enemy.

The other two switch positions adjust the volume for noisy environments. It is used in the vicinity of vehicle operation, etc. where it is necessary to increase the volume of full scale.

4. Noise Limiter

The noise limiter is controlled by the mode switch, except for the "■" and "⊗" positions, the noise is off. The radio set is operating in the intermittent (low power) mode. In this mode the handset will not produce the noise of the receiver. In the "■" and "⊗" positions, the receiver noise is clearly audible in the handset when the radio set does not receive a signal. The noise limiter effect does not impair the sensitivity of the radio receiver. If the radio set switch is switched to the "Δ", "◊", "□", the noise is switched off, and the radio set switches to so-called "power-saving" reception.

5. PTT Switch

This switch is located on handset.

The handset has a key to press the radio set to switch to transmit (fig. 14).

6. Signalling

There are two buttons on the handset above the PTT button (fig.13).

When the radio set is switched to the transmit mode any of these buttons, the radio set sends a beep tone.

7. Checking the battery during operation

During the operation of the radio set, especially during the time when the operating time of the battery pack is approaching the end of the charge, check occasionally, especially when transmitting, that the red light on the radio set control panel (Figure13) does not illuminate. When permanent light, it signals a the battery pack is almost discharged. The battery needs to be replaced or recharged!

8. Safety

During operation of the set, especially when operating in vehicles, with a rod antenna, when operating with a suspension antenna and directional antennas, care must be taken not to interfere with the wiring of overhead electric wires, the railways or the street traffic. There is a risk of electric shock!

9. Termination of operation

After shutting down the radio set by turning the mode switch switch to "◊". No other controls need to be altered. Disconnect the antenna and the handset. Both are placed in the bag in the prescribed manner (Chapter 5, paragraph 1).

If the unit is to be out of service for a long period of time, the 19-pole radio and electro-acoustic transceiver connectors, the antenna coaxial connectors of the radio set and the impedance transformer must be covered with protective plastic caps (Figure14).

CHAPTER 6

TECHNICAL TREATMENT

1. General provisions

To extend the life of the kit, it is necessary to follow these guidelines:

1. For the life of the radio set, it is necessary to strictly follow the instructions given in the previous sections.
2. Do not expose the kit unnecessarily to intense heat, sunlight, dust, rain, corrosive environments and excessive vibration.
3. Keep the radio kit dry and clean. The handset especially must be protected from rain and water.
4. The connectors of the radio set must be kept clean. Cleaning should be done with a dry cloth or brush. To clean the contacts of the 19-pin connector on the radio set panel, the battery must always be disconnected!
5. Do not attempt to move the rotary switches, buttons, etc. beyond their end stops. Do not to exert excessive force.
6. If the radio set is out of service (when carrying it, etc.), it is necessary to protect the connectors with protective caps.
After operation, make sure that the mode switch is set to "o"!
7. Do not carry the radio set by the connecting cables or the antenna.
8. All cables of the radio set must not be bent into excessively sharp angles. This can significantly reduce their operating lifetime. Do not use excessive force when pulling the suspension or directional antenna! Do not disconnect the cable connectors by pulling on the cable!
9. The whip antennas must not be subject to frequent bending. Turning of whip antennas to a smaller diameter than the width of the bag is not allowed!
10. The strap ends attached to the attachment pins of the radio set or battery pack must not be overloaded in the direction of the axis of the pivot pins, otherwise deformation of the terminals may occur.
11. When the radio set is stored for a long time, all parts of the kit must be stored in the shipping container, except for the battery packs which should be regularly recharged during storage.

2. Operating instructions for the battery pack

1. The complete cabinet QN 732 10 ensures the serviceability of the RF-10 radio set within the temperature limits -50°C to $+70^{\circ}\text{C}$.
2. For operation, the battery pack should always be upright.
3. The charging operation can be performed at a temperature of about 0°C to $+45^{\circ}\text{C}$. The most suitable temperature when charging up is $20 \pm 5^{\circ}\text{C}$.
4. The battery pack is discharged before charging with a current of 2A to a fall of $5.0\text{V} \pm 0.5\text{V}$ when using the XN 250 36 charger.
5. The battery pack is charged with a constant current. The charging time is 12 hours at a current of 450mA – when using the charger 3QP 669 03.
6. Overcharging battery packs shortens their life. When charging, it is advisable to check the battery temperature in the cabinet. When overcharging, overheating occurs!
7. Charge indication for battery packs produced before September 1, 1979: When the test button is pressed on the battery pack lid, the lamp lights up.
8. You can check the status of the battery pack by using the KZ-10 (see Chapter 4, section 2a).
9. During storage, the battery capacity decreases by about 25% in 15 days from the last charge, and it is important to check the status of the battery pack before using the kit. After a period longer than 15 days since the last charge, it is necessary to recharge the battery prior to its use.
10. Before using, remove the plastic cap and clean the connector with a clean cloth or brush.
11. Replacing the fuse. Using a screwdriver or the wrench provided in the kit, unscrew the two screws of the top box cover. In the window of plastics moulding inside the lid, attach a new fuse wire which is supplied with the kit. The operator can replace the fuse after the warranty period.
12. Replacement of each individual battery within the battery pack should not be carried out by a RF-10 operator. If the battery pack does not work satisfactorily or the operating time is too short, it is necessary to pass the battery pack to a workshop for inspection.
13. If the radio sets are out of service, always check they are shutdown – the "o" position of the mode switch.
14. The battery pack is provided with a self-adhesive label to record the date of charging and the current number of charges. This information must be recorded after each charging of the battery by specifying the day the charging was completed. Once this label is full, replace the label with the replacement in the kit and enter the total number of previous charges in its side section. One table is enough for twenty charges. After each charge, examine and clean the battery pack contacts.
15. Only for battery packs produced before September 1, 1979: with the battery pack connected to the battery charger, the operator can not use the test button to turn on the bulb. (In case of a breakage of the fuse there will be no indication).

3. Basic treatment

1. Keep the radio set dry and clean and especially the handset must be protected from rain and water.
2. Contacts and the connectors must be kept clean. Cleaning should be done with a dry cloth or brush. When cleaning the contacts of the 19-pin connector on the radio set panel, the battery must always be disconnected!
3. The wire antennas should be protected from corrosion once a year by means of resistin BL.
4. Once every six months, it is necessary to unscrew the vents of the radio set and battery packs, dry the set for at least one hour at a temperature of up to 50 ° C.
5. For reasons of facilitating the 19-pin connector, it is necessary to lightly lubricate the threads of the panel connector with frost-resistant grease every 3 months.
6. The vents of the radio set cabinet and a dust-contaminated cabinet must be cleaned with a dry brush. Mud can be cleaned off with clean water directly on the radio set or at the battery pack. In the case of soiling, it is necessary to unscrew and clean the vents in clean gasoline and dry after cleaning.
7. It is necessary to preserve the ML replacement once a year: the pins of the radio set and the battery packs, the head of the screws holding the panel of the set and the lid of the battery pack, the locks, the connecting pins for the battery, the ejecting clip for the battery and the sliding surfaces of the hinges.
8. If the radio dampers are immersed in water, the connector contacts and radio link cabinet assembly and battery packs must be cleaned immediately with clean water, brush off any mud and dirt. After drying, apply a thin layer of frost-resistant Konkor on the functional surfaces of the connector and the connecting mechanism.
9. A special key is provided in the box of the spare parts set (fig. 1, item 15). The use of this key while maintaining the set assembly is evident from fig.24.

4. Technical treatment No. 1

It is necessary to carry out the technical treatment No. 1 once a quarter every year (regardless of whether the set is deployed or not) or after each deployment of more than 7 days.

The part of the technical examination No. 1 is to carry out all the work of basic treatment according to points 1 to 8. Additionally, inspection the kit of accessories, attachments and replace any defective items.

The radio set is subjected to a parameter check by the KZ-10 control device according to Chapter 4 of the operating instructions. The check of important parameters (sensitivity, power output, power supply, voltage of the battery pack) is informative and simple, intended only for technical treatment No. 1. Control allows you to decide whether or not it is eligible for repair.

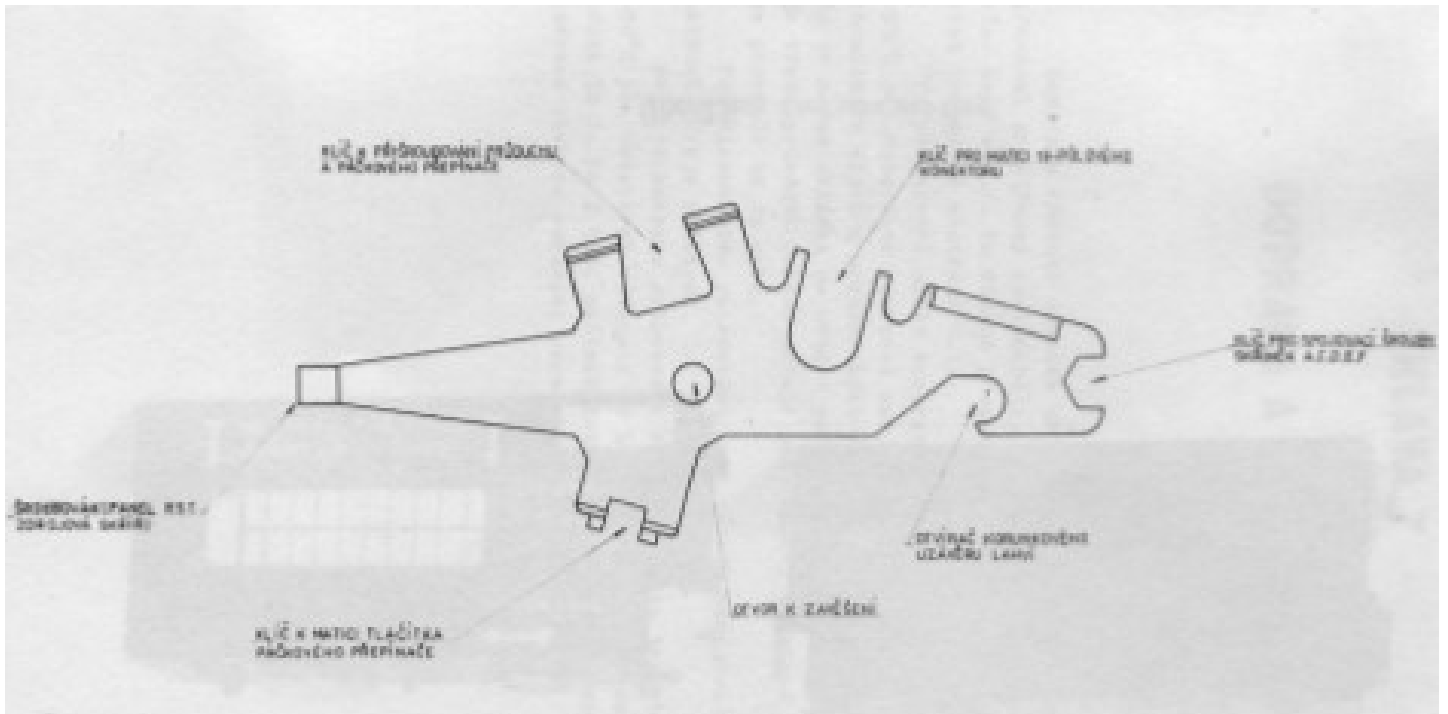

Figure 24: Special key

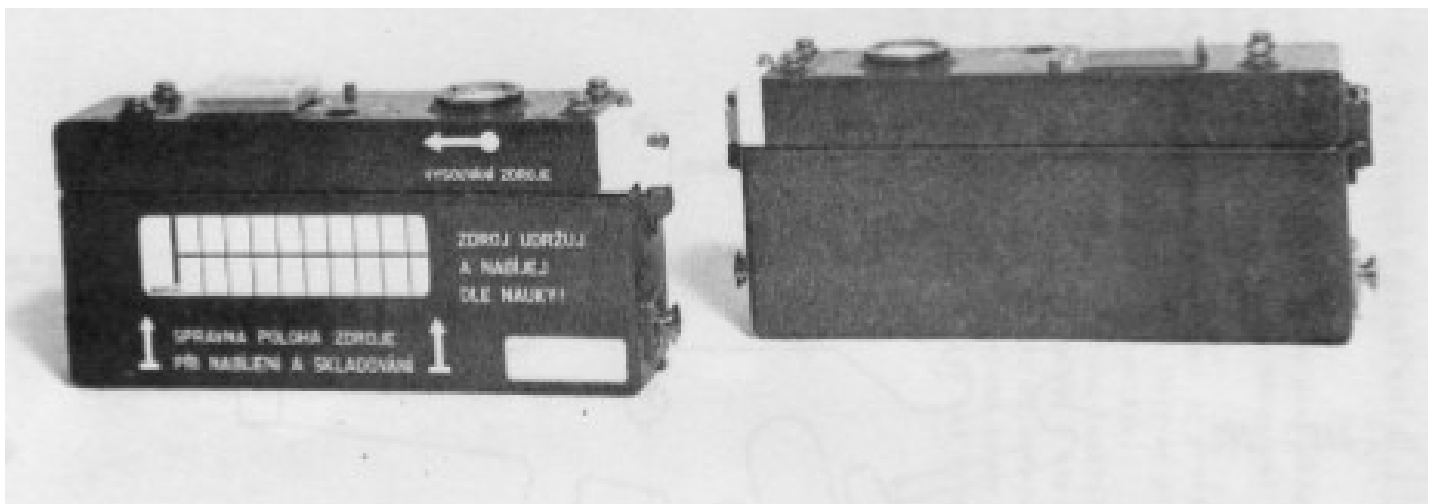

Figure 25: Battery pack

CHAPTER 7

TRANSPORTATION AND STORAGE

The radio set kit can be transported by all common means of transport (road vehicles, railway vehicles, railways, aircraft, boats, etc.). After a long transportation in the shipping container, it is necessary to carry out the technical treatment c.1.

During storage, the set tolerates a long-term ambient temperature of -22°C to $+35^{\circ}\text{C}$ with a relative humidity of up to 75% in dust-free environments without chemical influences and mechanical vibrations. The sets in the shipping container can be stacked up to a maximum of 5 pieces. During storage, it is necessary to carry out the maintenance of the battery according to Chapter 6 of the Statutes 2. TO 1 must be carried out once a year.

In case of long-term storage, it is necessary to store battery packs separately for reasons of charging battery packs.

For short-term storage, the set tolerates a temperature of -35°C to $+50^{\circ}\text{C}$ at 98% relative humidity. After such storage, TO 1 must be performed. After 2 hours of acclimatisation under normal conditions, the radio sets will fill the basic parameters and TTP requirements.

APPENDIX 1 TABLE OF DEFECTS AND FAULTS

No.	Fault	Cause	Removal method
1	2	3	4
1	radio sets turned on but no indicator lamp	a) discharged battery b) the battery pack fuse is blown c) Dirty contacts of the battery pack connector or radio set cabinet	a) recharge/replace the battery pack b) Replace the fuse c) Clean the contacts
2	Operating lamp flashes, radio switched to receive without signal Mode switch in position "■", no sound is heard in the handset	a) faulty handset, cable or connectors (item 3 Figure14) b) Defect within the radio set; frequency synthesizer etc.	a) Replace the handset b) Perform TO 1 and decide on further action. Radio set out of operation
3	The radio set is switched to the "⊗" mode switch, the green lamp is off	a) A defect within a radio set, a faulty transmitter; Frequency switchgear, etc. b) defective bulb – can establish a connection over a short distance	a) Perform TO 1 and decide on further action radio set out of operation b) The radio set is fully operational
4	The radio set work, transmitter checked, when using short or long-range antennas, small range	a) a broken antenna b) Short circuit in the connection cable c) Damaged antenna transformer	a) check the mechanical and electrical connections b) Replace antennas for others c) Defective, fix
5	The radio set is operating normally, the operating time is very short	a) the battery pack is discharged b) Battery pack failure	a) Recharge battery pack b) recondition or replace battery pack
6	The radio set is operating normally receiving or transmitting broadcasting stations	a) Handset failure b) Cable damage c) Damage to connectors	a) Replace handset, clean connectors b) Check the cables c) Check the acoustic kit on the meter, clean the connectors

Table of restricted channels

On some of the radio set channels, the reception sensitivity is worse than the specifications.

Sensitivity (0.5 to 1) μV of the channels

Sensitivity (1 to 2) μV of channels

APPENDIX 2 RADIO SET RF-10 BLOCK DIAGRAM

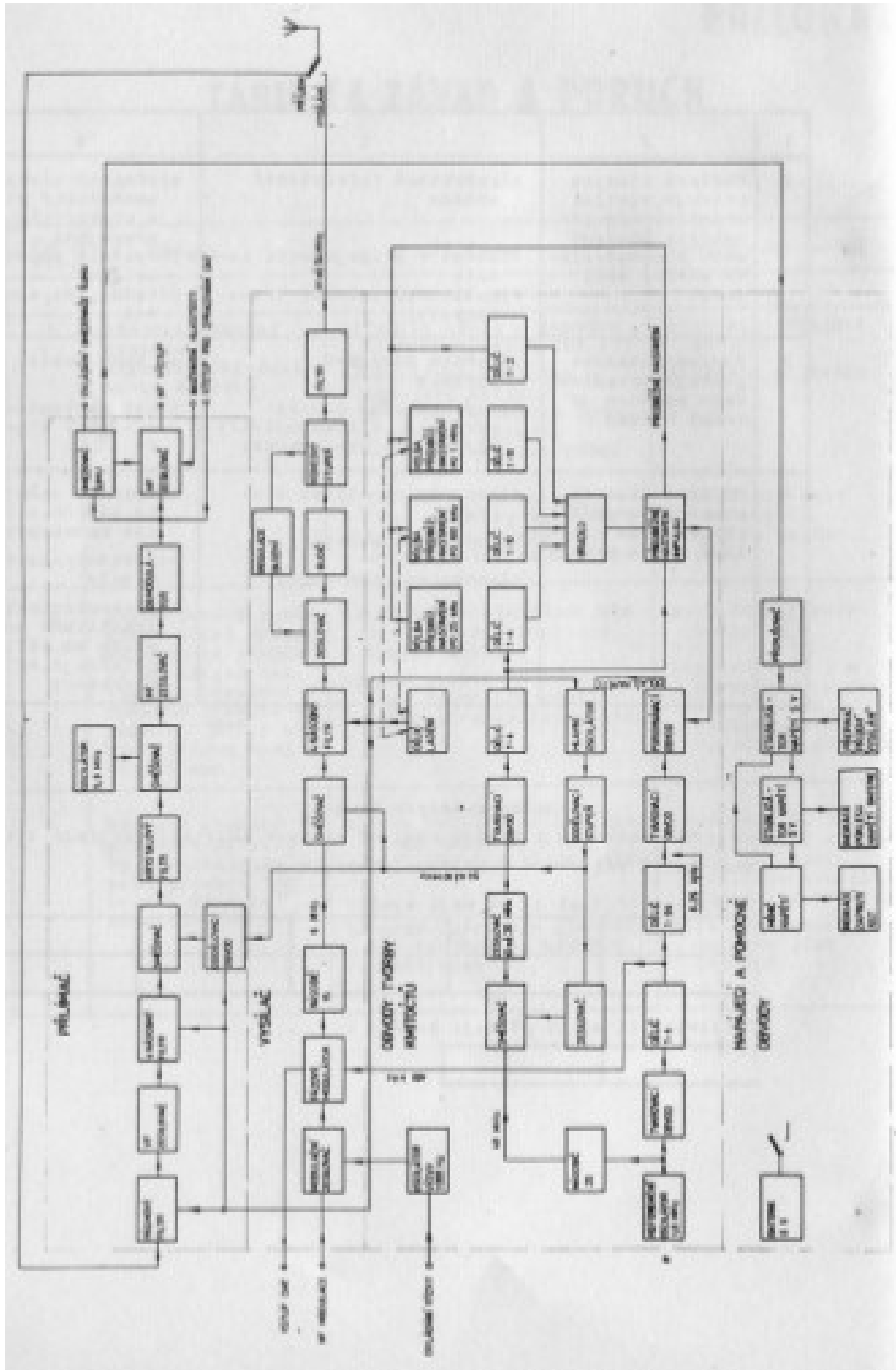

Table of Contents

GUARANTEE CONDITIONS.....	2
INTRODUCTION.....	3
CHAPTER 1 SPECIFICATIONS.....	4
CHAPTER 2 DESCRIPTION OF EQUIPMENT AND KIT LIST.....	5
1. Composition of the kit.....	5
2. Functional description.....	7
a) Receiver.....	7
b) Transmitter.....	7
c) Frequency generation circuits.....	7
d) Supply and auxiliary circuits.....	7
CHAPTER 3 DESCRIPTION OF USAGE.....	9
1. Storing and wearing a radio set.....	9
a) Storing.....	9
b) Wearing.....	9
2. Preparation & Operation.....	18
a) Battery connection.....	18
b) Carrying in a bag.....	19
3. Description of the radio set control panel.....	20
4. Handset connection.....	22
5. Choice and connection of antennas.....	22
a) The 1.5 m whip antenna.....	22
b) The 0.5m whip antenna (shortened).....	23
c) Suspension antenna.....	23
d) Horizontal directional antenna (half rhombic).....	23
e) Horizontal directional antenna (long wire).....	23
6. Checking the radio set before operation.....	29
a) Checking the receiver.....	29
b) Checking the transmitter.....	29
c) Battery control.....	29
CHAPTER 4 TEST EQUIPMENT KZ-10.....	30
1. Description.....	30
a) Connecting the control device.....	30
2. Check the radio set.....	31
a) Checking the battery pack.....	31
b) Checking radio set current consumption.....	31
c) Checking reception sensitivity.....	31
d) Checking the transmitter power.....	31
3. Voltage measurement.....	31
CHAPTER 5 OPERATION.....	32
1. Tuning radio sets.....	32
a) General.....	32
b) Frequency setting procedure.....	32
2. Setting the mode switch.....	32
3. Volume control.....	33
4. Noise Limiter.....	33
5. PTT Switch.....	33
6. Signalling.....	33
7. Checking the battery during operation.....	33
8. Safety.....	33
9. Termination of operation.....	33
CHAPTER 6 TECHNICAL TREATMENT.....	34
1. General provisions.....	34
2. Operating instructions for the battery pack.....	35
3. Basic treatment.....	36
4. Technical treatment No. 1.....	37
CHAPTER 7 TRANSPORTATION AND STORAGE.....	38
APPENDIX 1 TABLE OF DEFECTS AND FAULTS.....	39

Table of restricted channels.....	40
APPENDIX 2 RADIO SET RF-10 BLOCK DIAGRAM.....	41